



**DESIGN AND TECHNOLOGY**

**9705/31**

Paper 3

**October/November 2009**

**3 hours**

Additional Materials:      Answer Booklet/Paper  
   A range of design drawing equipment  
   A3 Drawing paper (5 sheets)



**READ THESE INSTRUCTIONS FIRST**

Write your Centre number, candidate number and name on all the work you hand in.  
Write in dark blue or black pen.  
You may use a soft pencil for any diagrams, graphs or rough working.  
Do not use staples, paper clips, highlighters, glue or correction fluid.

**Section A**

Answer any **two** questions from **one** of the Parts **A**, **B** or **C**.

**Section B**

Answer **one** question.

All dimensions are in millimetres.

The instruction 'discuss' denotes that you should:

- examine critically the issues raised by the question;
- explain and interpret these issues as appropriate;
- introduce evidence wherever possible to support conclusions of arguments.

At the end of the examination, fasten all your work securely together.

The number of marks is given in brackets [ ] at the end of each question or part question.

This document consists of **11** printed pages and **1** blank page.



## Section A

Answer **two** questions from **one** of the Parts **A**, **B** or **C**.

## Part A – Product Design

- 1 Fig. 1 shows a prototype design for a bowl to hold after-dinner sweets.

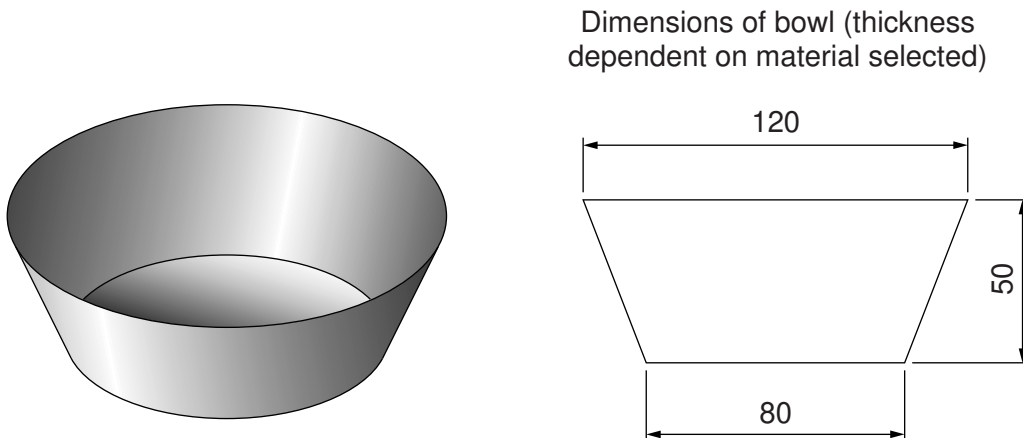

**Fig. 1**

- (a) State a suitable material for the bowl and give **two** reasons for your choice. [3]
- (b) Describe, using notes and sketches, how you would make the prototype bowl. [8]
- (c) Explain what changes may be necessary to the design, in the manufacturing method used and in the material selected, if 10,000 bowls were required. Use notes and sketches to support your answer. [9]

2 Fig. 2 shows a fizzy drinks can.

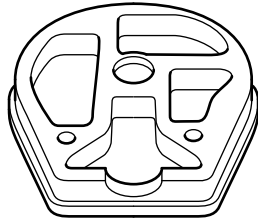
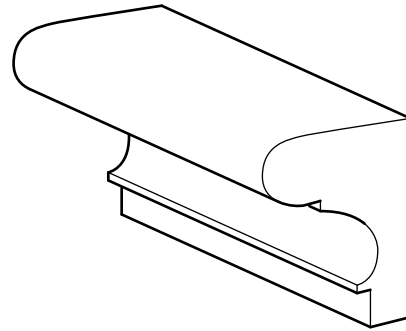

Fig. 2

- (a) Give **three** reasons why drinks cans are suitable for mass production. [3]
- (b) Explain **two** reasons why most designer training shoes are **not** mass produced. [4]
- (c) State **three** products that are designed to be one-off or single unit products. [3]
- (d) Discuss how the following can affect the scale of production of a product.
- tooling/equipment
  - assembly
  - labour skills
- [10]

3

Hardwood picture frame section.  
Process: Profile forming



Electric plug case.  
Process: Compression moulding

Aluminium window frame for  
greenhouse section.  
Process: Extrusion

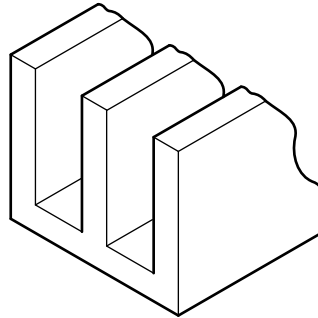

**Fig. 3**

Choose **two** of the items shown in Fig. 3 and for each:

- (a) use notes and sketches to describe the manufacturing process that relates to the chosen item; [7 x 2]
- (b) explain why the process is particularly suitable for the production of the item. [3 x 2]

## Part B – Practical Technology

4 Fig. 4 shows a typical stress/strain graph for mild steel.

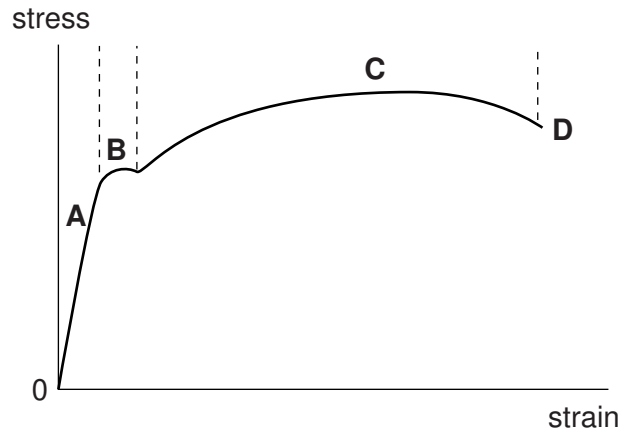

Fig. 4

- (a) (i) Describe what is happening in the region **A**. [2]  
 (ii) Describe what is happening in the region **B**. [2]  
 (iii) Describe what is happening in the region **C**. [2]  
 (iv) Describe what is happening at point **D**. [2]

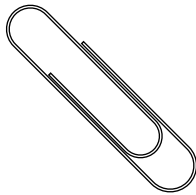

Fig. 5

Fig. 5 shows a wire paper clip.

- (b) Identify and explain **two** properties of a material used to make a wire paper clip. [6]  
 (c) Use sketches and notes to describe a simple workshop test for torsion. [6]

5 (a) Calculate:

- (i) the resistance in an arrangement if the voltage is 6V and the current is 6 mA; [1]
- (ii) the current in an arrangement if the voltage is 12V and the resistance is 33k $\Omega$ ; [1]
- (iii) the current in an arrangement if the voltage is 6V and the resistance is 82 $\Omega$ . [1]

- (b) (i) Calculate the power of a lamp rated at 240V, 0.25 A. [2]
- (ii) A 3kW fire is designed to run on a 250V supply.  
Calculate the current that it will draw from the supply and the resistance of the element of the fire. [3]

(c) Describe the function and explain the working of the following:

- relay;
- micro switch;
- Darlington pair;
- LDR.

Give an example of use in each case. [4 x 3]

6 Use labelled sketches and diagrams to describe **five** of the following mechanisms.  
For each mechanism, state a product that includes the mechanism.

- ratchet
- worm and worm wheel
- lever
- cam
- crank
- gear train

[5 x 4]

Part C – **Graphic Products**

**7** For **five** of the following, use examples to explain when and why a designer would make use of them:

- exploded drawings;
- planometric;
- one-point perspective;
- 3D charts;
- pictograms;
- thick and thin line technique.

[5 x 4]

**8** Construct a cam profile and displacement diagram from the following information.

- cam shaft diameter 20 mm
- in-line wedge-shaped follower
- minimum distance from centre to follower 50 mm
- anti-clockwise rotation
- 0° – 120° rise uniform velocity
- 120° – 180° dwell
- 180° – 360° fall simple harmonic motion

[20]

9 Orthographic views of a video camera are shown in Fig. 6.

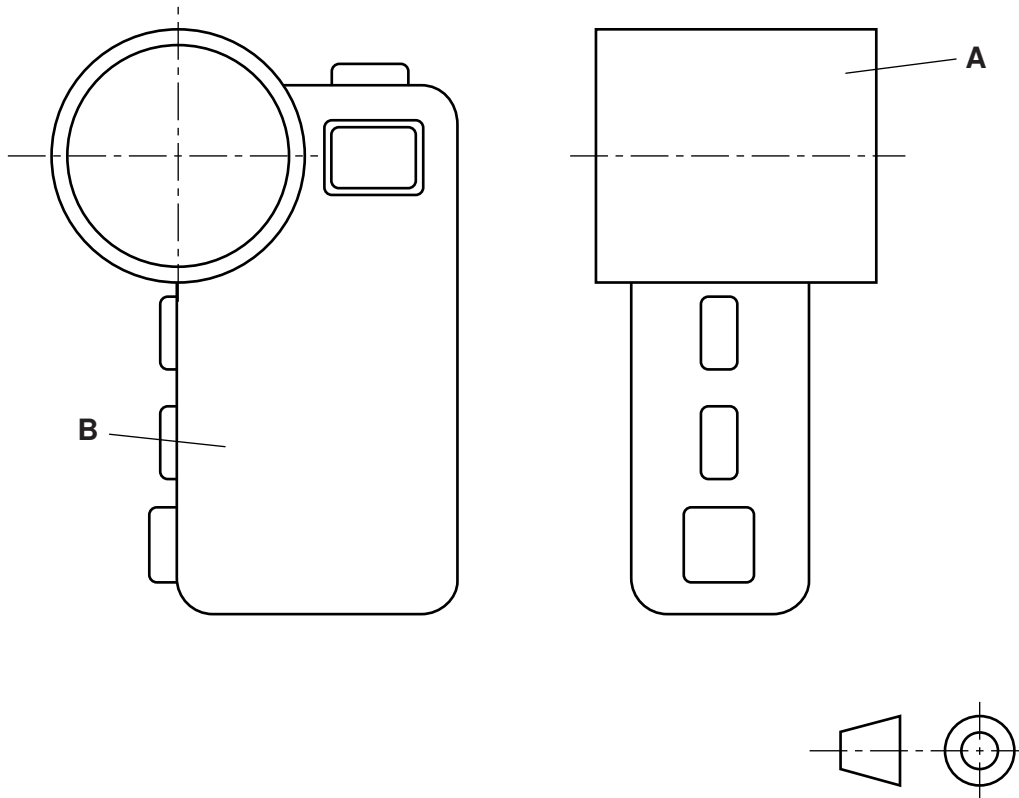

**Fig. 6**

The manufacturer requires a high-quality rendered presentation drawing to promote the product.

Use a combination of freehand and instrument techniques to draw approximately full size, an isometric view of the video camera.

Select a view that gives most detail and render the drawing to show that part **A** is polished chrome and part **B** is matt textured. [20]



**Section B**

Answer **one** question on the A3 paper provided.

You should approach the design question of your choice in the following manner:

**Analysis**

Produce an analysis of the given situation/problem, which may be in written or graphical form. [5]

**Specification**

From the analysis produce a detailed written specification of the design requirements.

Include at least five specification points other than those given in the question. [5]

**Exploration**

Use bold sketches and brief notes to show your exploration of ideas for a design solution, with reasons for selection. [25]

**Development**

Show, using bold sketches and notes, the development, reasoning and composition of ideas into a single design proposal. Give details of materials, constructional and other relevant technical details. [25]

**Proposed solution**

Produce drawings of an appropriate kind to show the complete solution. [15]

**Evaluation**

Give a written evaluation of the final design solution. [5]

[Total: 80]

- 10 Visiting speakers or lecturers to a school or college often require the use of a laptop computer and a projector to deliver their presentations.

Design a floor standing unit that can support a laptop computer and a projector, which could be used by visiting speakers or lecturers.

The stand must be able to be folded or disassembled for ease of storage.

To assist you in your answer, details of a laptop computer and projector are given in Fig. 7 and anthropometric data is given in Fig. 8.

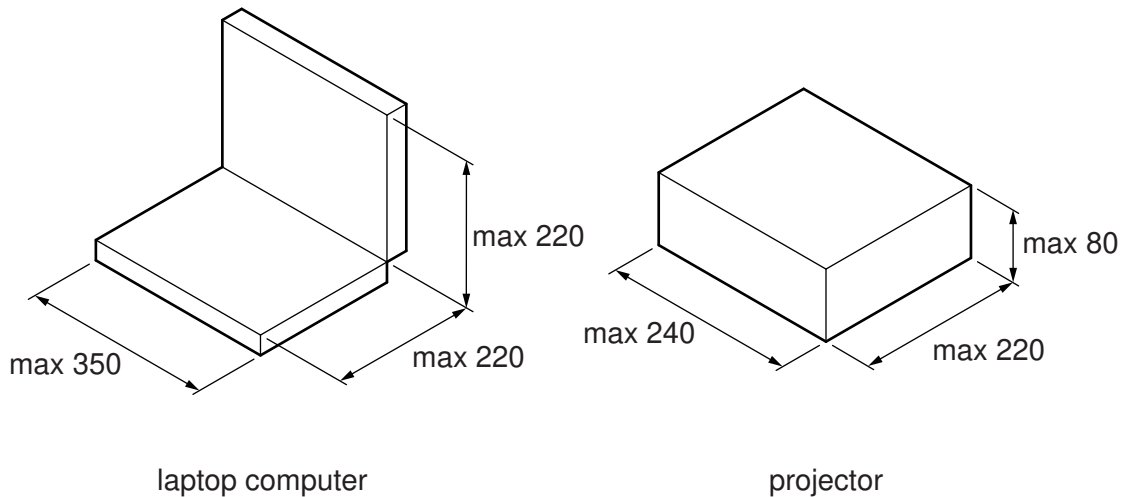

Fig. 7

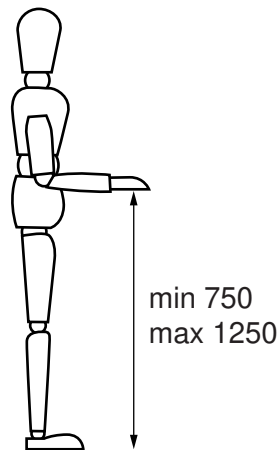

Fig. 8

- 11** A school has a small orchard of fruit trees. The fruit trees need to be pruned every year.

Design a device to cut branches up to 25 mm diameter.  
The device must use a shearing action to cut the branch.

The device must be able to cut branches to a maximum of 3.5 m from the ground.

To assist you with your answer, anthropometric data is given in Fig. 9.

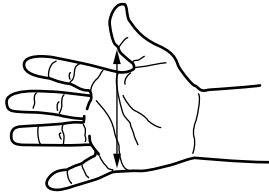

Hand width  
min 85  
max 125

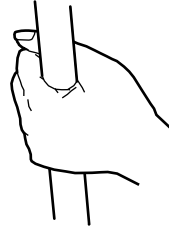

Comfortable grip size  
min Ø20  
max Ø32

**Fig. 9**

- 12** As part of a Local Community project, your school/college is to increase the use of its facilities by running a restaurant in the evenings. It will have 20 dining tables.

You are to design a menu holder, made mainly from card, which will be placed in the centre of a dining table.

It must:

- hold a menu made from A5 size card;
- include a name of your choice for the Restaurant and a simple logo;
- hold a single fresh flower.

---

Permission to reproduce items where third-party owned material protected by copyright is included has been sought and cleared where possible. Every reasonable effort has been made by the publisher (UCLES) to trace copyright holders, but if any items requiring clearance have unwittingly been included, the publisher will be pleased to make amends at the earliest possible opportunity.

University of Cambridge International Examinations is part of the Cambridge Assessment Group. Cambridge Assessment is the brand name of University of Cambridge Local Examinations Syndicate (UCLES), which is itself a department of the University of Cambridge.