

UNIVERSITY OF CAMBRIDGE INTERNATIONAL EXAMINATIONS
General Certificate of Education
Advanced Subsidiary Level and Advanced Level

DESIGN AND TECHNOLOGY

9705/01

Paper 1

Specimen paper for examination from 2007

3 hours

Additional Materials: Answer Booklet/Paper

READ THESE INSTRUCTIONS FIRST

If you have been given an Answer Booklet, follow the instructions on the front cover of the Booklet.
Write your answers and working on the separate Answer Booklet/Paper provided.
Write your Centre number, candidate number and name on all the work you hand in.
Write in dark blue or black pen.
You may use a soft pencil for any diagrams, graphs, or rough working.
Do not use staples, paper clips, highlighters, glue or correction fluid.

Section A

Answer **one** question.

Section B

Answer **one** question.

Section C

Answer **one** question.

You are advised to spend **30 minutes** on each of Sections A and B and **2 hours** on Section C.

At the end of the examination, fasten all your work securely together.
The number of marks is given in brackets [] at the end of each question or part question.
All dimensions are in millimetres.

This document consists of **10** printed pages.



Section A

Answer **one** question from this section.

- 1 Fig. 1 shows a puppet theatre which is to be made from wood in a school workshop.

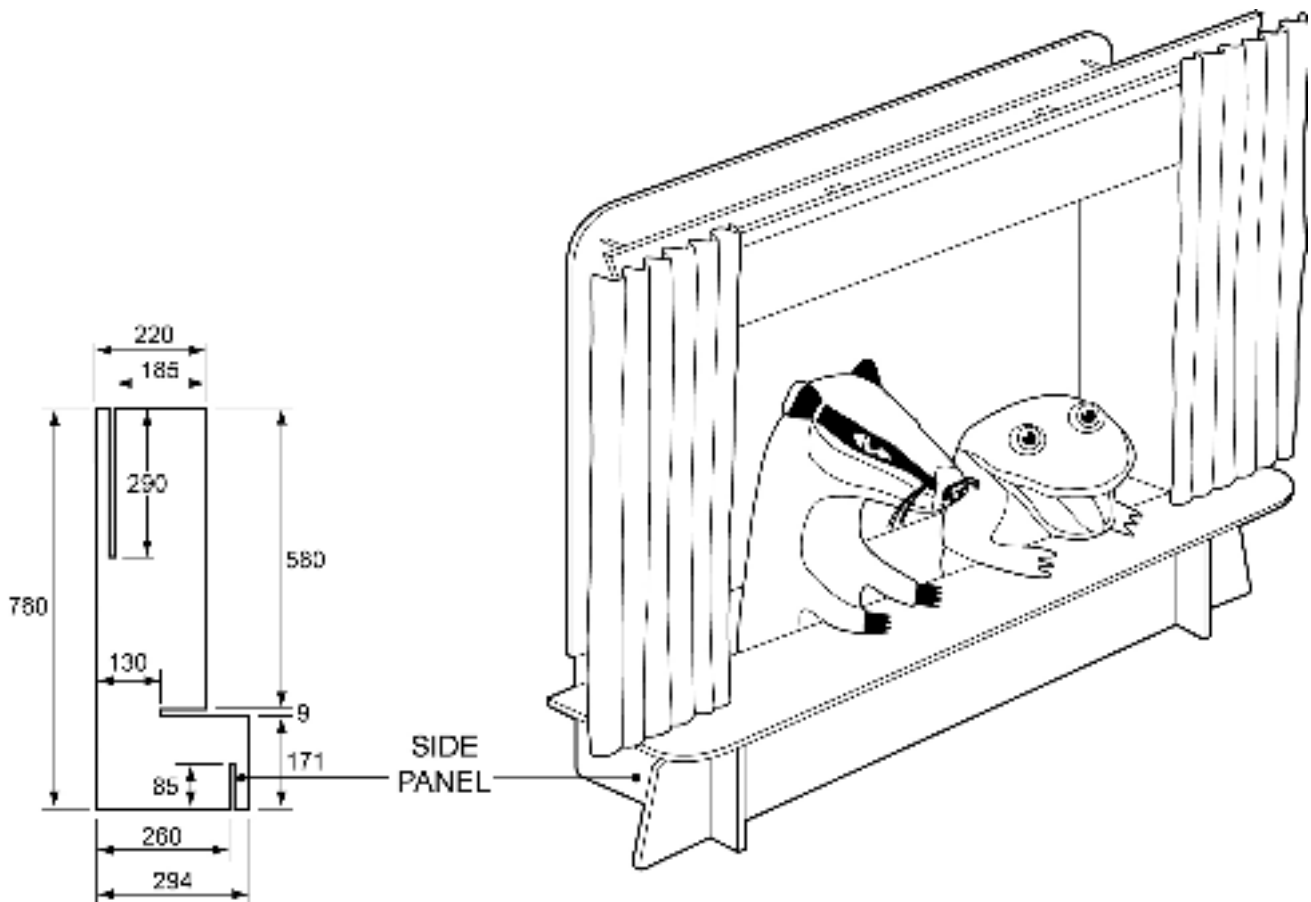

Fig. 1

- (a) Name a suitable wood for making the puppet theatre and give **one** reason for your choice. [2]
- (b) Use notes and sketches to describe:
- (i) how one of the side panels would be marked out on the wood; [6]
 - (ii) how the side panel would be cut and finished to the required shape; [6]
 - (iii) how a suitable surface finish would be applied to the wood. [6]

You must give details about the tools, equipment and processes involved and the safety precautions that have to be undertaken at each stage.

2 Fig. 2 shows a bathroom fitting which is to be made from sheet material in a school workshop.

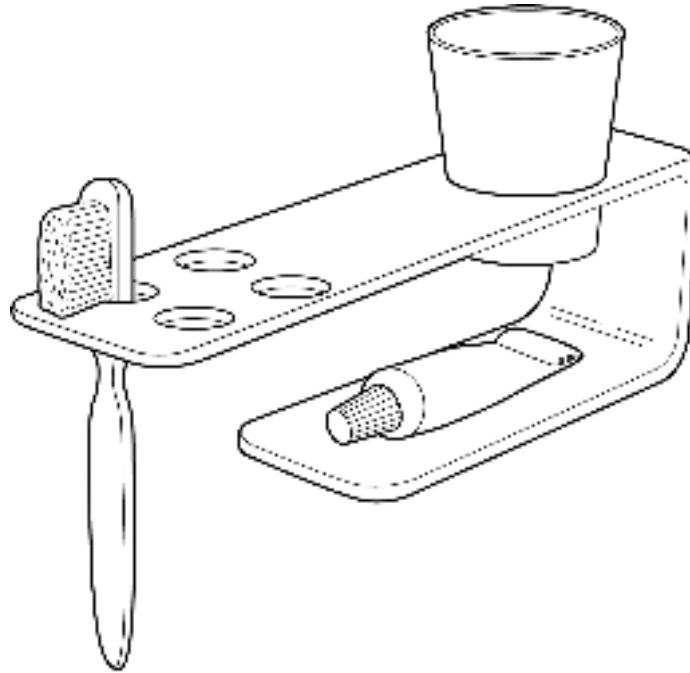

Fig. 2

- (a) Name a suitable sheet material for making the fitting and give **one** reason for your choice. [2]
- (b) For the material that you have identified in (a) use sketches and notes to describe:
- (i) how the material would be marked out; [6]
 - (ii) how the material would be cut and finished to the required shape; [6]
 - (iii) how the material would be bent. [6]

You must give details about the tools, equipment and processes involved and the safety precautions that have to be undertaken at each stage.

- 3 Fig. 3 shows a point of sale display box to hold chocolate bars. The top can be folded open to display the chocolate bars. The box is to be made from one piece of card in a school workshop.

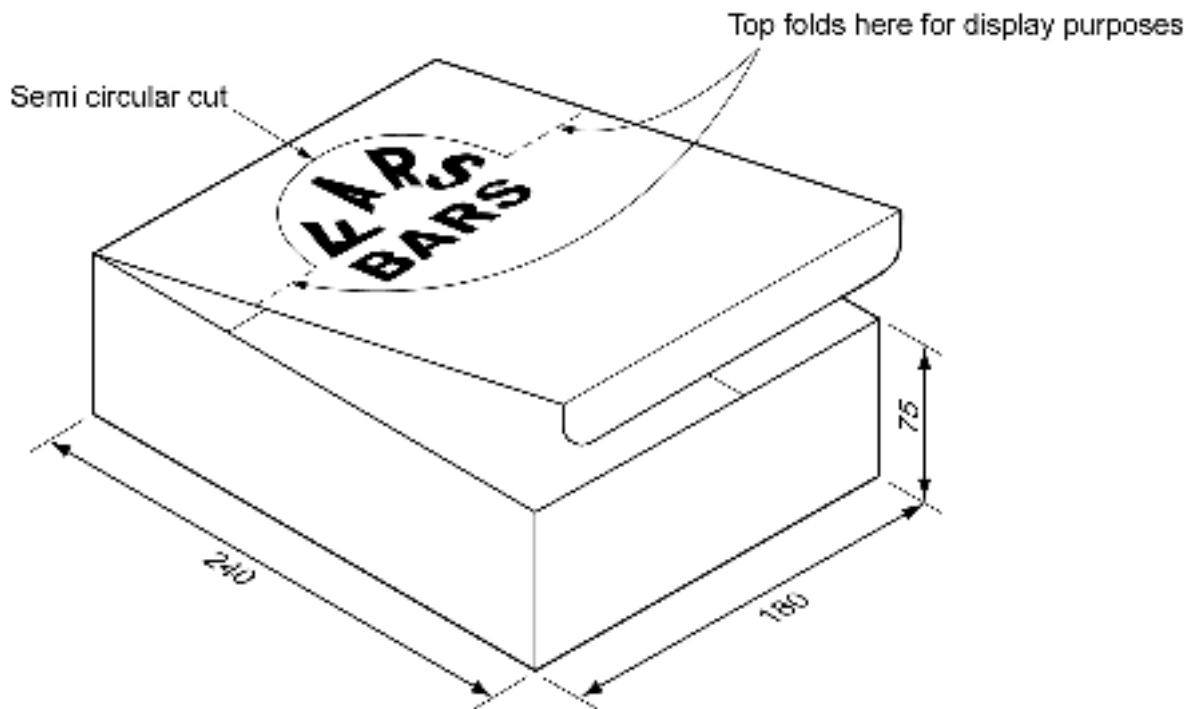

Fig. 3

- (a) Name a suitable card for making the display box and give **one** reason for your choice. [2]
- (b) Use notes and sketches to describe how the corners of the box could be joined together using slot in tabs. [6]
- (c) Sketch, to an appropriate scale, the development (net) required to make the box. [6]
- (d) Use notes and sketches to describe how the development (net) would be marked out on the card and then cut out. [6]

You must give details about the tools, equipment and processes involved and the safety precautions that have to be undertaken at each stage.

Section B

Answer **one** question from this section.

- 4 A range of bird box designs is shown in Fig. 4.

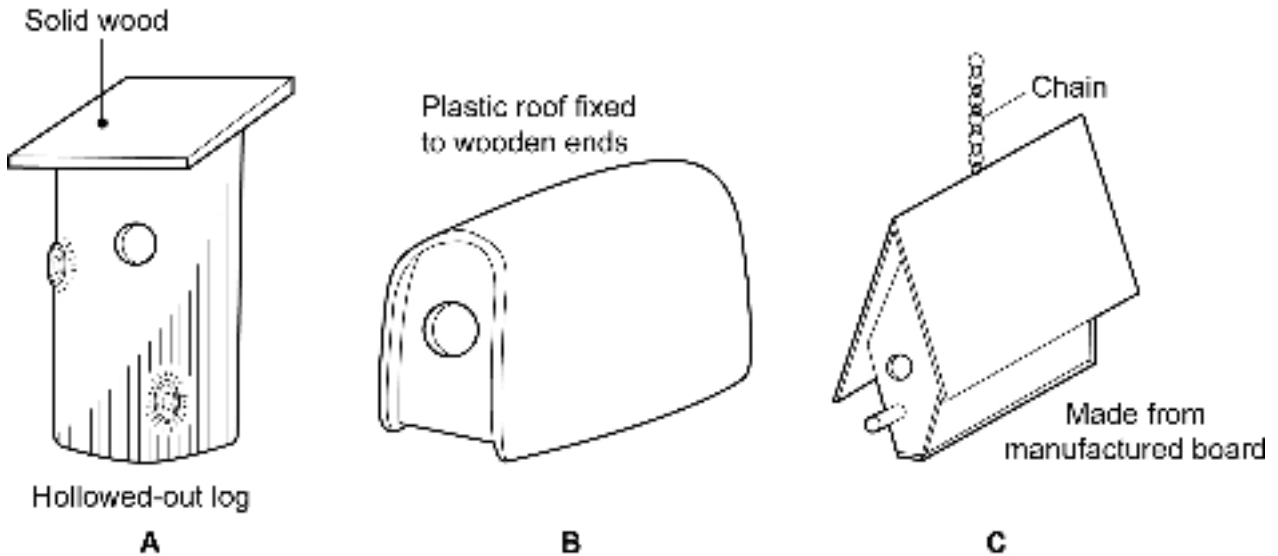

Fig. 4

- (a) Explain why the roof of design **B** has been curved. [2]
- (b) The use of manufactured board in design **C** has caused problems.
Describe **two** problems that could occur with manufactured board when it is used outside. [4]
- (c) Explain how the two problems that you have identified in (b) could be overcome. [6]
- (d) Discuss the suitability of the three bird box designs for use in a garden environment. Your answer should:
- (i) analyse the given situation and identify three relevant issues raised by the question; [3]
 - (ii) explain why you consider these three issues to be relevant; [3]
 - (iii) contain specific examples/evidence as support for your conclusions. [2]

5 Shops often give carrier bags like the ones shown in Fig. 5 to their customers.

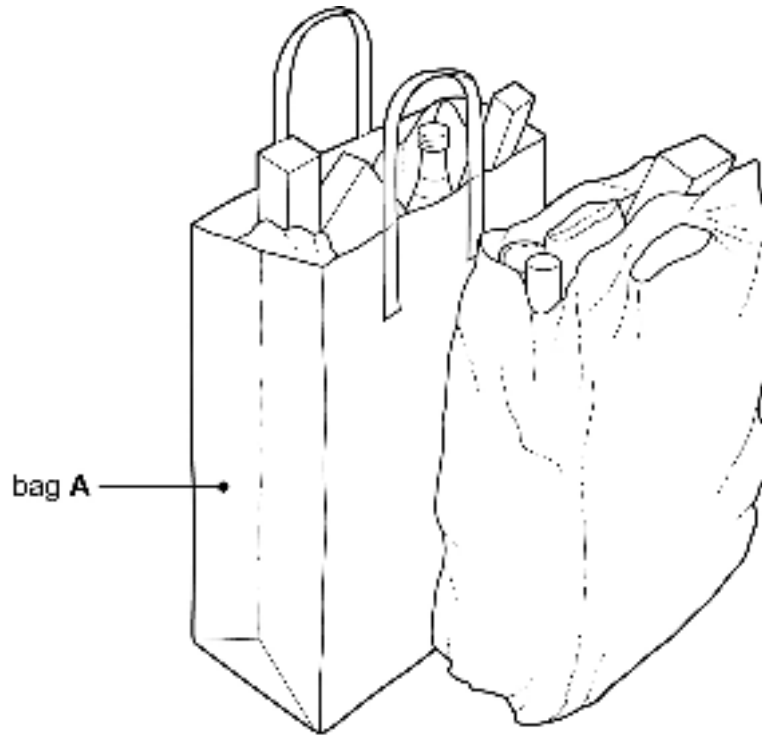

Fig. 5

- (a) Explain the purpose of the folds on the sides of bag A. [2]
- (b) Describe two problems that could occur with carrier bags when they are full of shopping. [4]
- (c) Explain how the two problems that you have identified in (b) could be overcome. [6]
- (d) Discuss the relative merits of different types of carrier bags in relation to the issues of conservation of resources and the role of recycling. Your answer should:
- (i) analyse the given situation and identify three relevant issues raised by the question. [3]
- (ii) explain why you consider these three issues to be relevant. [3]
- (iii) contain specific examples/evidence as support for your conclusions. [2]

- 6 Lighting is often required in garden situations. Fig. 6 shows a reproduction Japanese lantern which takes its style from traditional garden and temple lamps used 500 years ago. The lantern is made in three separate parts; each part is made from a ferrous metal. Light shines through the square holes.

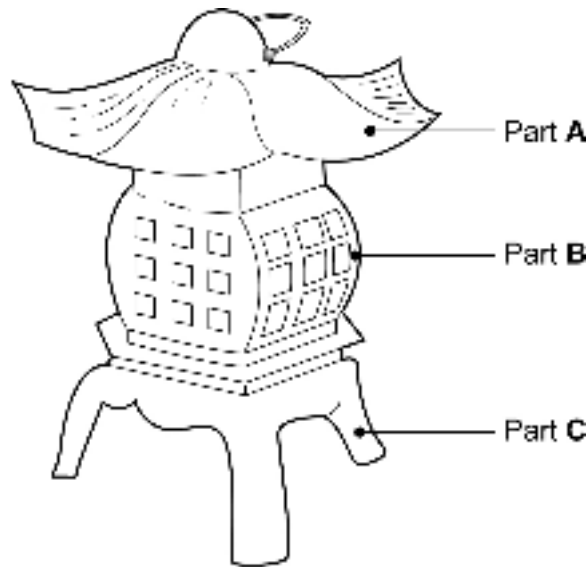

Fig. 6

- (a) Explain why the lantern has been made in three separate parts. [2]
- (b) The use of ferrous metal in the design has caused problems.
Describe two problems that can occur when a ferrous metal is used outside. [4]
- (c) Explain how the two problems you have identified in (b) could be overcome. [6]
- (d) Discuss the safety implications involved in using mains electricity as the energy source to provide light in the lantern. Your answer should:
- (i) analyse the given situation and identify three relevant issues raised by the question; [3]
 - (ii) explain why you consider these three issues to be relevant; [3]
 - (iii) contain specific examples/evidence as support for your conclusions. [2]

Section C

Answer **one** question from this section.

Your response to **each** of the five parts of the question you choose to answer in this section should be presented on one side of A4 plain paper.

Where you are asked to develop a design you must show, using bold sketches and notes, the development, reasoning and composition of your ideas into a single design proposal. You must give details about materials, construction and other relevant technical aspects.

- 7 Fig. 7 shows an initial idea for a can crusher.
The can crusher is to be made from mild steel and will crush a can to a quarter of its original height.

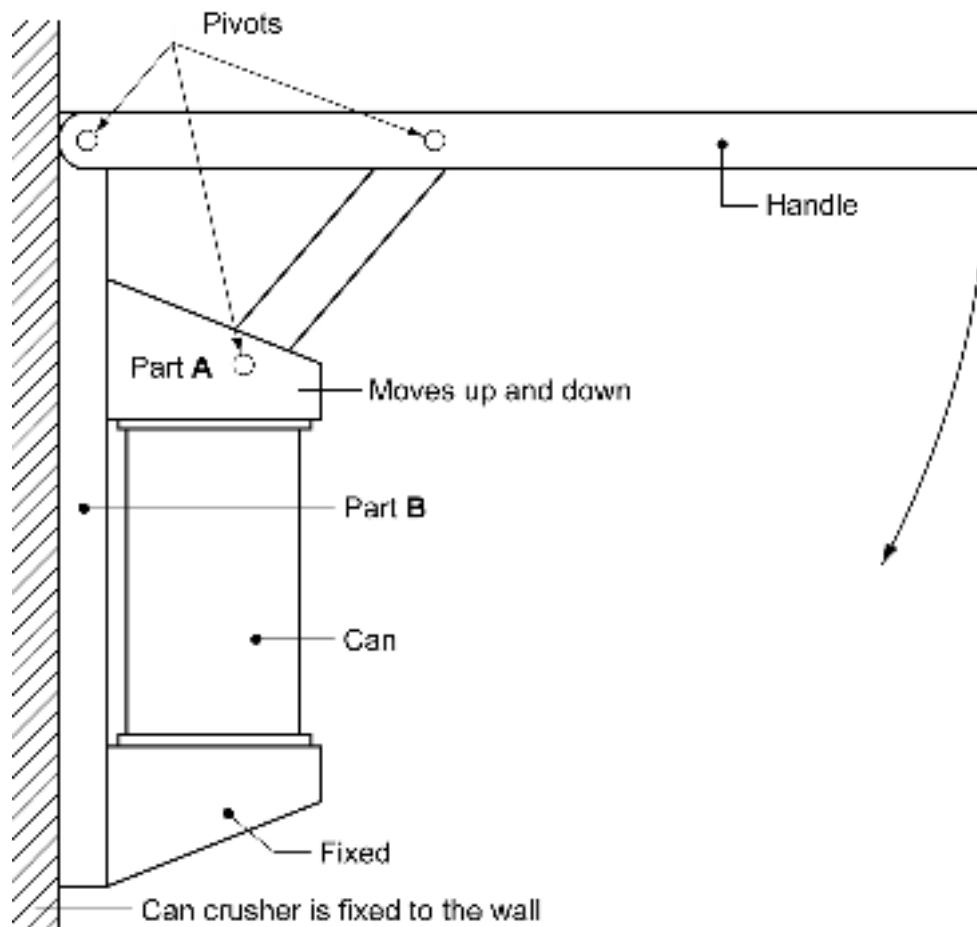

Fig. 7

- (a) Using notes and sketches develop the idea to show the design features that will allow:
- (i) the parts of the can crusher to pivot at the points indicated on Fig. 7, full details must be given about the joining method to be used; [16]
 - (ii) part A to slide up and down on part B when the crusher is operation; [16]
 - (iii) the can crusher to be fixed to a wall. [16]
- (b) Using notes and sketches develop the design of the handle so that it is more ergonomic. [16]
- (c) Produce a pictorial rendered drawing of the complete can crusher which shows all of the principal features that you have designed in (a) and (b). [16]

- 8 Food and drink carriers are often used by fast-food restaurants. Fig. 8 shows an initial idea for a carrier to hold two plastic cups. The carrier is to be made from one piece of card.

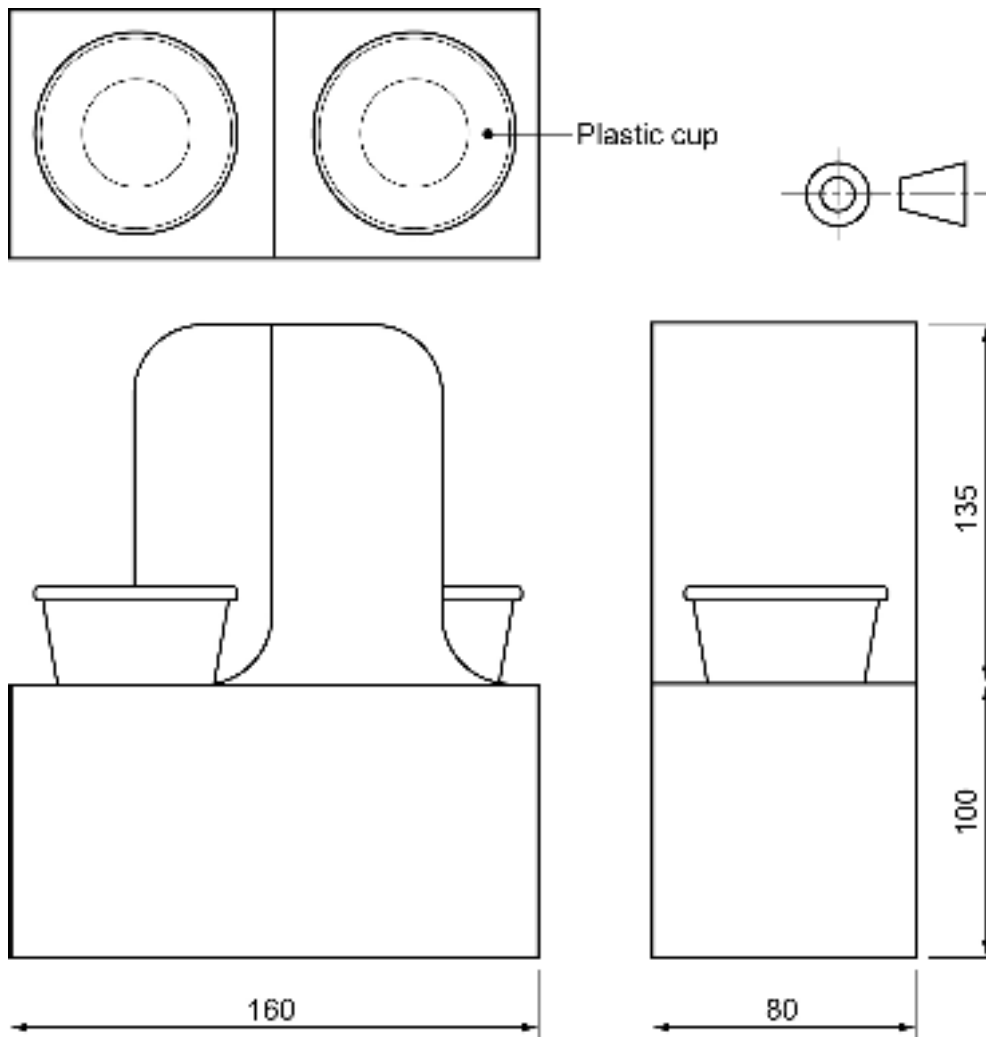

Fig. 8

- (a) Using notes and sketches develop the idea to show the design features that will allow:
- (i) the carrier to be flat packed for easy transportation and storage. The carrier must be easily assembled for use without the need for additional glue or adhesive tape; [16]
 - (ii) two carriers to be joined together without the need for additional glue or adhesive tape; [16]
 - (iii) the carrier to be easily carried by one hand when holding two cups full of hot liquid. [16]
- (b) Draw, to an appropriate scale, the one piece development (net) required to make your design for the carrier. Clearly show all glue tabs and fold lines. [16]
- (c) Produce a pictorial rendered drawing of the complete carrier which shows all of the principal features that you have designed in (a). [16]

- 9 Wind powered mechanical toys are often used in gardens to add movement and interest.

Fig. 9 shows an incomplete idea for part of a wind powered toy. The toy is made from wood apart from the shaft which is metal.

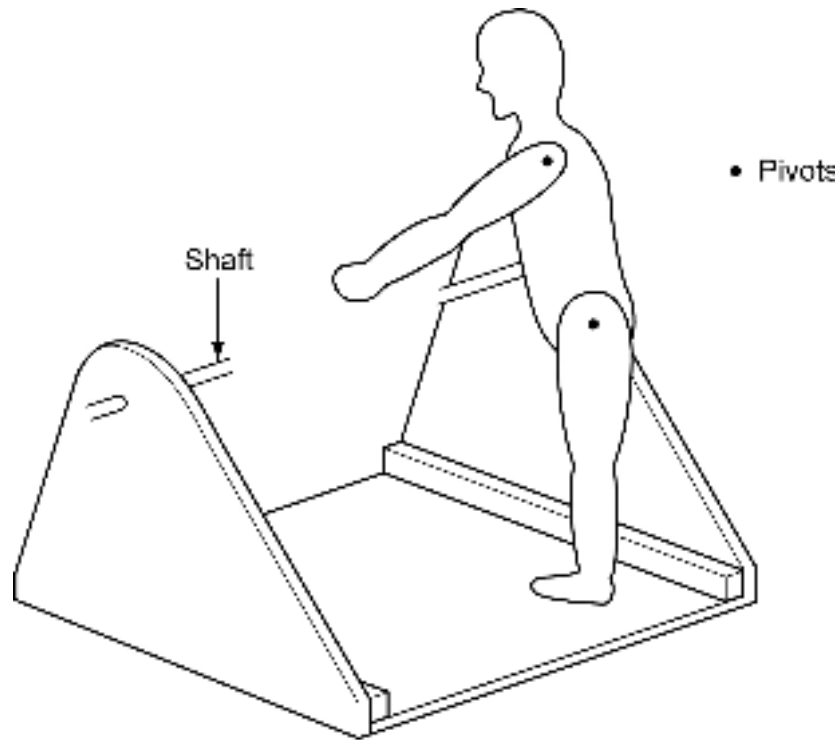

Fig. 9

- (a) Using notes and sketches develop the idea to show:
- (i) the design feature that will make the metal shaft rotate when the wind blows; [16]
 - (ii) the mechanism that will make the person move when the shaft rotates; [16]
 - (iii) the design feature that will enable the toy to be easily attached and removed from a 50 mm square wooden post. The post is 1500 mm long. [16]
- (b) Using notes and sketches develop a design for a free standing wooden base which will support the 50 mm square post and enable the mechanical toy to be moved to different places in a garden. [16]
- (c) Produce a pictorial rendered drawing of the complete wind powered toy which shows all of the principal features that you have designed in (a) and (b). [16]

Permission to reproduce items where third-party owned material protected by copyright is included has been sought and cleared where possible. Every reasonable effort has been made by the publisher (UCLES) to trace copyright holders, but if any items requiring clearance have unwittingly been included, the publisher will be pleased to make amends at the earliest possible opportunity.

University of Cambridge International Examinations is part of the University of Cambridge Local Examinations Syndicate (UCLES), which is itself a department of the University of Cambridge.