



UNIVERSITY OF CAMBRIDGE INTERNATIONAL EXAMINATIONS  
General Certificate of Education Ordinary Level

www.PapaCambridge.com

**PHYSICS**

**5054/03**

Paper 3 Practical Test

**May/June 2008**

CONFIDENTIAL INSTRUCTIONS

**2 hours**

**Great care should be taken to ensure that any confidential information given does not reach the candidates either directly or indirectly.**

**No access to the Question Paper is permitted in advance of the examination.**



If you have any problems or queries regarding these Instructions, please contact CIE  
by e-mail: [International@cie.org.uk](mailto:International@cie.org.uk),  
by phone: +44 1223 553554,  
by fax: +44 1223 553558,  
stating the Centre number, the nature of the query and the syllabus number quoted above.

This document consists of **9** printed pages and **3** blank pages.



### Instructions for preparing apparatus

These instructions detail the apparatus required for each experiment in this paper. No additional apparatus is permitted to the Question Paper in advance of the examination session.

### Number of sets of apparatus

In addition to a few spare sets, the minimum number of sets of apparatus to be provided should be sufficient to enable candidates to spend 20 minutes with the apparatus for each of Questions 1, 2 and 3, and one hour with the apparatus for Question 4. The order in which candidates answer the questions will be determined by the Supervisor. Candidates may spend one hour circulating around Questions 1, 2 and 3, followed by an hour on Question 4, or vice versa.

It is assumed that candidates will supply their own calculator and geometrical instruments, such as a set square,  $0^\circ$  to  $180^\circ$  protractor, pair of compasses and 30 cm rule. Candidates should be advised in advance that they may, if they wish, use quartz wristwatches with stopwatch facilities, providing that such wristwatches afford the required precision.

### Instructions for the supervision of the examination

The Supervisor, who may be a Physics teacher, is responsible for the administration of the examination according to the procedures detailed in the Handbook for Centres. In all instances, a Physics teacher should be present. Preferably, this teacher should have been responsible for the preparation of the apparatus. Two invigilators must be present at all times: it is not acceptable for a teacher who has been responsible for preparing the candidates for this paper to be the sole Supervisor or Invigilator.

Supervisors may make the following announcement at the start of the examination.

'The Examiners do not want you to waste time when you are unable to do any experiment. Any candidate who is unable to get results with an experiment may ask for help. The extent of this help will be reported to the Examiners, who may make a deduction of marks.'

Supervisors should note that a candidate may only be given enough assistance to allow some raw readings or observations to be made. On no account should any assistance be given with the treatment or analysis of these readings and observations.

Supervisors may draw to the attention of the candidates any significant deviation between the apparatus provided and that detailed in the Question Paper, particularly where diagrams are given in the paper.

Candidates should be reminded that all their work should be written on the Question Paper. Rough paper must not be used.

The Supervisor must complete the Report at the back of these Instructions. Details should be given of any significant deviation between the apparatus used and that specified in these Instructions. A sample set of results can often help Examiners. A copy of this Report must be included in **each** packet of scripts.

**Question 1**

**Items to be supplied by the Centre (per set of apparatus, unless otherwise specified).**

Five identical coins.

30 cm rule with a mm scale.

Card on which is written the mass of 1 coin.

**Notes**

- 1 The coins should be identical, round and the largest size that is readily available.
- 2 All candidates should be given the same type of coin. Spare coins should be available.
- 3 The mass of one coin should be written on the card in the format “ $m = \dots\dots\text{g}$ ”. The mass of the coin should be given to 2 significant figures.
- 4 At the changeover Supervisors should check that all items are still present.

**Information required by examiners**

Typical values for the mass, diameter and thickness of a coin.

**Question 2**

Items to be supplied by the Centre (per set of apparatus, unless otherwise specified).

100 cm<sup>3</sup> Pyrex beaker.

250 cm<sup>3</sup> beaker containing at least 100 cm<sup>3</sup> of water at room temperature.

Supply of hot water e.g. kettle to be shared between candidates.

100 cm<sup>3</sup> measuring cylinder.

-10°C to 110°C liquid in glass thermometer, readable to the nearest °C.

Plastic stirrer.

Stand, boss and clamp.

**Notes**

- 1 The 100 cm<sup>3</sup> beaker should be labelled A. If there is no 50 cm<sup>3</sup> mark on the beaker, Supervisors should provide one, using a permanent marker pen.
- 2 There should be sufficient supplies of hot water to ensure that candidates do not have to carry hot water across the laboratory e.g. one kettle between four sets of apparatus. Supervisors should bring the water to the boil just before changeover so the next candidates have a supply of water at a sufficiently high temperature.
- 3 The thermometer should be held in the stand, clamp and boss so that candidates can easily place it in beaker A as shown in Fig. 2.1.

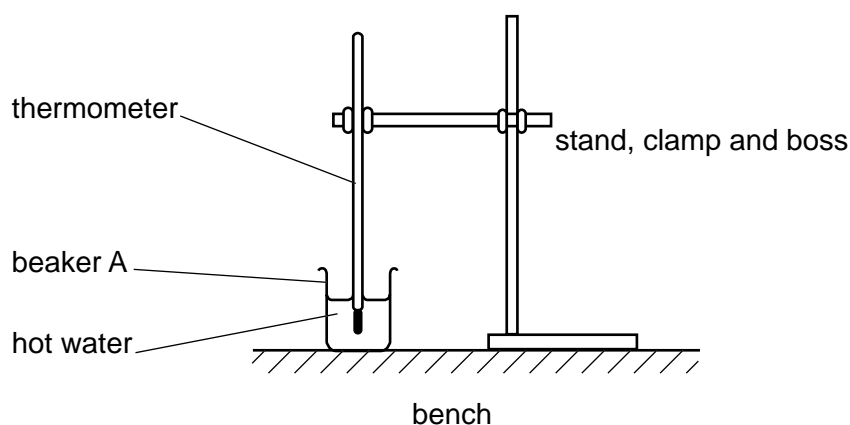

**Fig. 2.1**

- 4 At the changeover, Supervisors should;
  - discard the water from beaker A and the measuring cylinder,
  - replenish the supply of water at room temperature, if necessary,
  - ensure that the supply of hot water has just boiled.

**Information required by examiners**

None.

**Question 3**

**Items to be supplied by the Centre (per set of apparatus, unless otherwise specified).**

Converging lens of focal length 15 cm.

Cross-wire object.

Lamp to illuminate the object.

White screen of approximate dimensions 20 cm by 20 cm.

Lens holder.

Metre rule.

**Notes**

- 1 The cross-wire object should be formed by using a 20 cm square piece of card or board. A hole of diameter 2 cm should be made in the board and two small pieces of thin wire should be glued so that they cross the hole along two perpendicular diameters.
- 2 The object and the screen should be supported so that they can stand perpendicular to the bench. This should be done attaching blocks of wood to the base of the object and screen.
- 3 The centre of the hole, the lamp and the centre of the lens when it is supported in the holder should be at the same height above the bench.
- 4 The apparatus should be in a dimly lit area of the laboratory and the lamp should be bright enough so that candidates can see images formed on the screen.
- 5 At the changeover the Supervisor should dismantle any apparatus that has been left set up by the candidate.

**Information required by examiners**

None.

**Question 4**

**Items to be supplied by the Centre (per set of apparatus, unless otherwise specified)**

4.5 V d.c. power supply, e.g. three 1.5 V dry cells in a suitable holder.

Red light emitting diode.

Three resistors of values, 270  $\Omega$ , 330  $\Omega$  and 470  $\Omega$ .

Switch or plug key.

Milliammeter capable of recording a current to a precision of at least 0.1 mA. A 10 mA analogue or a 20 mA digital meter is suitable.

Voltmeter capable of recording a potential difference of up to 3.0 V to a precision of at least 0.01 V. A 5V analogue meter is suitable as is a 20 V digital meter.

Seven connecting leads to enable the Supervisor to connect up the circuit shown in Fig. 4.1.

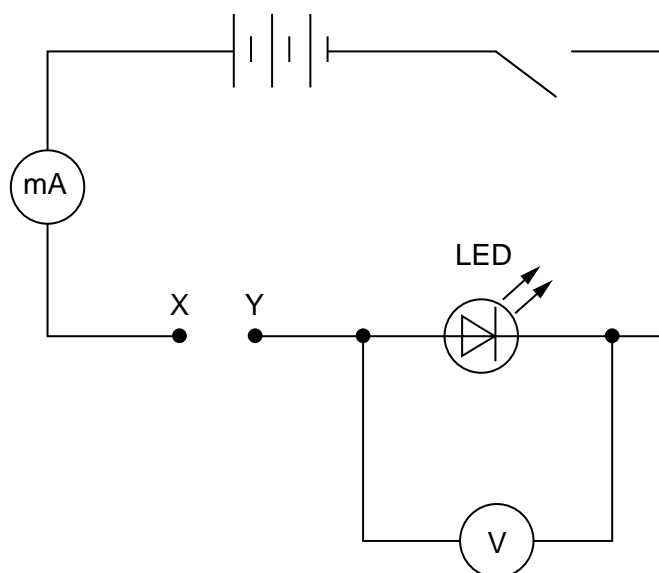

**Fig. 4.1**

Two additional connecting leads.

**Notes**

- 1 The LED and the resistors should have suitable terminations to enable them to be connected to the remainder of the circuit.
- 2 The resistors should be marked with their values.
- 3 The apparatus should be set up by the Supervisor as shown in Fig. 4.1. The points X and Y should be clearly labelled.
- 4 At the changeover, the Supervisor should remove the resistors from the circuit and open the switch. The apparatus should still be set up as shown in Fig. 4.1.

**Information required by examiners**

None.









**This form must be completed and returned with the Answer Booklets.**

### **REPORT ON PRACTICAL PHYSICS**

The Supervisor is asked to give the following details, using the space provided on page 12.

- (a)** Information required at the end of the test, as indicated in the Instructions.
- (b)** Any help given to a candidate.
- (c)** Any general difficulties encountered in preparing the apparatus.
- (d)** Any difficulties experienced by particular candidates. These should include reference to difficulties due to faulty apparatus or materials and accidental damage to apparatus or materials. Candidates should be identified by name and candidate number.

Other cases of hardship, such as disability or illness, should be reported to the Syndicate in the normal way.

The Supervisor is asked to provide a plan of the work benches, giving details by candidate numbers of the places occupied by the candidates for each session.

The plan and report should be enclosed in the envelope containing the answers of candidates. If more than one envelope is used, a copy of the report must be enclosed in each envelope.

#### **Declaration to be signed by the Principal**

The preparation of this practical examination has been carried out so as fully to maintain the security of the examination.

Signed .....

Name (in block capitals) .....

Centre Number .....

Centre Name .....



**Information required**

Typical values for the mass, diameter, and thickness of a coin:

mass = ..... g

diameter = ..... mm

thickness = ..... mm

**Details of difficulties and any help given to candidates**