



BUSINESS AND MANAGEMENT

9771/01

Paper 1 Business Concepts

May/June 2012

2 hours 30 minutes

Additional Materials: Answer Booklet/Paper

READ THESE INSTRUCTIONS FIRST

If you have been given an Answer Booklet, follow the instructions on the front cover of the Booklet.
Write your Centre number, candidate number and name on all the work you hand in.
Write in dark blue or black pen.
You may use a soft pencil for any diagrams, graphs or rough working.
Do not use staples, paper clips, highlighters, glue or correction fluid.

Section 1

Answer **all** questions.
The Insert contains the multiple-choice answer sheet on which you write your answers to Section 1.
For each question there are four possible answers **A, B, C** and **D**.
Choose the **one** you consider correct and record your choice **on the Insert**.
Each correct answer will score one mark. A mark will not be deducted for a wrong answer.

Section 2

Answer **all** questions.

Section 3

Answer **one** question.

You are advised to spend 25 minutes on Section 1, 1 hour 20 minutes on Section 2, and 45 minutes on Section 3.

At the end of the examination, fasten all your work securely together including your answers on the multiple-choice Insert.

The number of marks is given in brackets [] at the end of each question or part question.

This document consists of **12** printed pages and **1** Insert.



Section 1: Multiple Choice

Answer all questions in this section.

Record your answers on the Insert.

You are advised to spend 25 minutes on the 20 questions in this section.

- 1 According to the Boston Matrix model, a 'cash cow' is a product with:
- A high market share and high market growth.
 - B high market share and low market growth.
 - C low market share and high market growth.
 - D low market share and low market growth.
- 2 Which one of the following factors will be most likely to make the demand for a firm's product more responsive to an increase in its price?
- A A fall in the cost of producing the product.
 - B A reduction in the price of a complementary product.
 - C An increase in consumer incomes.
 - D Competitors decide not to raise their prices.
- 3 The best definition of 'cluster sampling' is when a sample is based on:
- A arranging the target population in order and then selecting respondents at regular intervals from the list.
 - B giving each member of the population an equal chance of being selected from a list of the whole target population.
 - C taking respondents from each non-overlapping group in the target population in the same proportion as they exist within the target population.
 - D using a two stage sample – selecting an area and then selecting, perhaps at random, respondents from that area.
- 4 A mobile ice-cream vendor sells 500 ice-creams each day for £2 each. The direct cost of making each ice-cream is £0.35. The average fixed cost per ice-cream at this level of daily sales is £0.60. The difference between daily contribution and daily profit is:
- A £165
 - B £300
 - C £525
 - D £1000

- 5 A business uses the declining balance method of depreciation for its fixed (non-current) assets. It purchases a new machine for £2m and uses a 35% rate of annual depreciation. The net book value of this machine after two years will be:
- A £600 000
 - B £700 000
 - C £845 000
 - D £1 300 000
- 6 Which one of the following statements best describes the vision of the Ethical Trading Initiative?
- A A world where all workers are free from exploitation and discrimination.
 - B All suppliers have to guarantee that only renewable sources of supplies are used.
 - C Global agreement by major manufacturers that all waste from production is recycled.
 - D Global agreement by major manufacturers to obey national laws covering consumer rights.
- 7 One of the claimed advantages of Management by Objectives (MBO) is:
- A once objectives have been established they do not have to be changed.
 - B once objectives have been established there is no need to undertake any further assessment of employee's performance.
 - C the clear sense of purpose given by well articulated objectives gives the organisation inflexibility.
 - D workers are encouraged to self-audit and to identify the skills needed to achieve the objectives set.

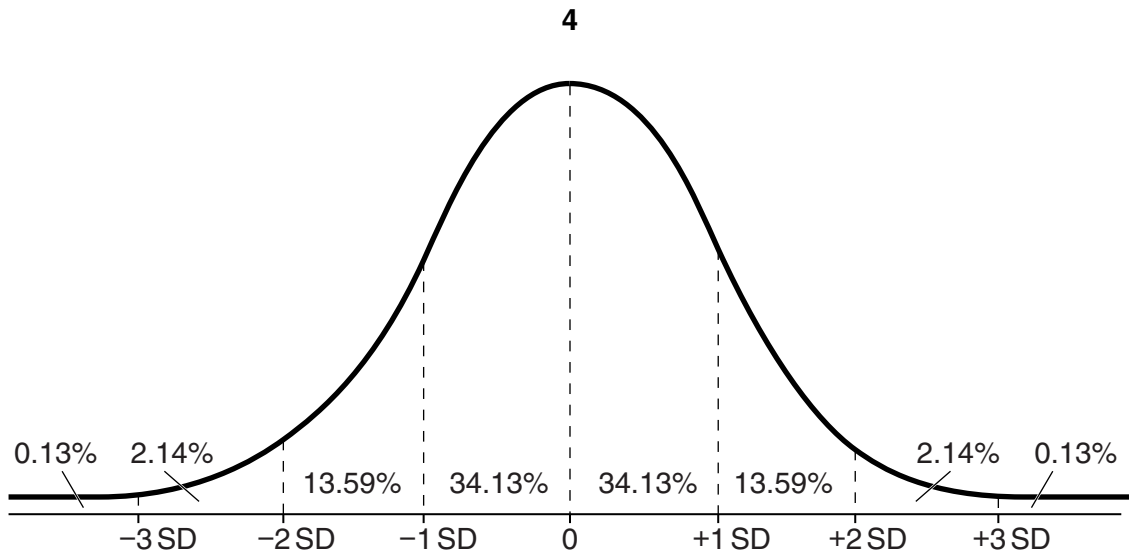

Figure 1: Percentage of results under portions of the normal curve

- 8 According to a bank, the time taken by its customers to use cash dispensing machines is normally distributed with a mean of 18 seconds and a standard deviation of 3 seconds. Using the information in Figure 1, what is the probability that any one randomly selected customer will take less than 12 seconds?
- A 2.14%
- B 2.27%
- C 13.59%
- D 37.72%

Total asset turnover ratio	2.5
Total assets of the business	£1.5 bn
Inventories (stocks)	£0.5 bn
Debtors (accounts receivable)	£0.75 bn

Table 1: Extract from a company's accounts

- 9 Based on data in Table 1, the Inventory Turnover ratio result is:
- A 3.75
- B 5
- C 7.5
- D 10

- 10 Based on data in Table 1, the Days' Sales in Accounts Receivable (Debt Collection Period) is:
- A 7.5 days.
 - B 73 days.
 - C 75 days.
 - D 100 days.

Cash IN:	
Cash sales	35 000
Received from debtors	23 000
Total cash IN	<i>not yet calculated</i>
Cash OUT:	
Labour	12 600
Materials	10 200
Fixed expenses	3 700
Total cash OUT	<i>not yet calculated</i>
Opening balance	(12 600)
Net cash flow	<i>not yet calculated</i>
Closing balance	X

Table 2: Cash flow forecast for a business, August 2012

- 11 Refer to Table 2. The value of X is:
- A (26 500)
 - B (18 900)
 - C 18 900
 - D 31 500
- 12 Which one of the following is an external economy of scale?
- A Bulk purchasing discounts as the business expands its scale of operations.
 - B Government grants that encourage other firms into the same locality.
 - C Improved industry-specific college training courses in the region.
 - D Lower wage rates due to demand for a key labour skill from local businesses.

	2010	2011
Total sales (units)	1.6m	1.7m
Total output (units)	1.5m	1.8m
Maximum capacity (units)	2m	2.2m

Table 3: Capacity and output data for a business

- 13** Using the data in Table 3, the rate of capacity utilisation between 2010 and 2011 in this business changed from:
- A** 75% to 82%
 - B** 80% to 77.3%
 - C** 75% to 77.3%
 - D** 80% to 82%
- 14** David McLelland's motivational needs theory proposed that an individual's specific needs are acquired over time and are shaped by one's life experiences. Which of the following ideas is most closely associated with this theory?
- A** Job enrichment needs
 - B** Need to achieve self-actualisation
 - C** Need for affiliation
 - D** Need for financial security
- 15** One of the reasons most frequently given for the increasing importance of Customer Relationship Management (CRM) is:
- A** attracting new customers increases sales, keeping existing customers just stops sales from falling.
 - B** it is easier to attract new customers with low prices than it is to keep existing ones with improved products.
 - C** it is cheaper to advertise to new customers than to existing customers.
 - D** it is cheaper to retain existing customers than it is to attract new customers.
- 16** One of the most likely benefits to a large business of adopting an ethical code is that:
- A** it reduces the risk of actions taken by employees that might damage the public image of the business.
 - B** it is legally binding so it becomes a criminal offence to break it.
 - C** it will give the business a unique public relations advantage.
 - D** it ensures that the business will not be accused of breaking important laws.

- 17 The most likely reason for Tesco opening its 'Fresh & Easy' stores in the US in 2008 was to:
- A benefit from low labour costs in this emerging market.
 - B benefit from the lack of competitors in the US market.
 - C gain from the appreciation of the sterling exchange rate when exporting products from the UK.
 - D use market development to achieve further sales growth.
- 18 In November 2010 the Bank of England's Monetary Policy Committee (MPC) decided to keep the official Bank Rate at 0.5%, having maintained the same rate since March 2009. The most likely reason for this was:
- A the rate of inflation measured by the Consumer Price Index had continually been above the original target set for the MPC by the Government.
 - B the MPC was worried that deflationary pressures might tip the economy into another recession.
 - C the MPC aimed to encourage an appreciation of sterling's external value.
 - D the MPC was worried about the high level of consumer saving and low level of consumer debt.

August 2011	Actual	Budget
Sales (units)	1570	1450
Selling price	£3	£2.90
Variable costs (total)	£2100	£2000
Fixed costs	£1200	£1340

Table 4: Budget data for a business

- 19 Based on the data in Table 4, the profit variance for August 2011 was:
- A (£545)
 - B £545
 - C £865
 - D £1410

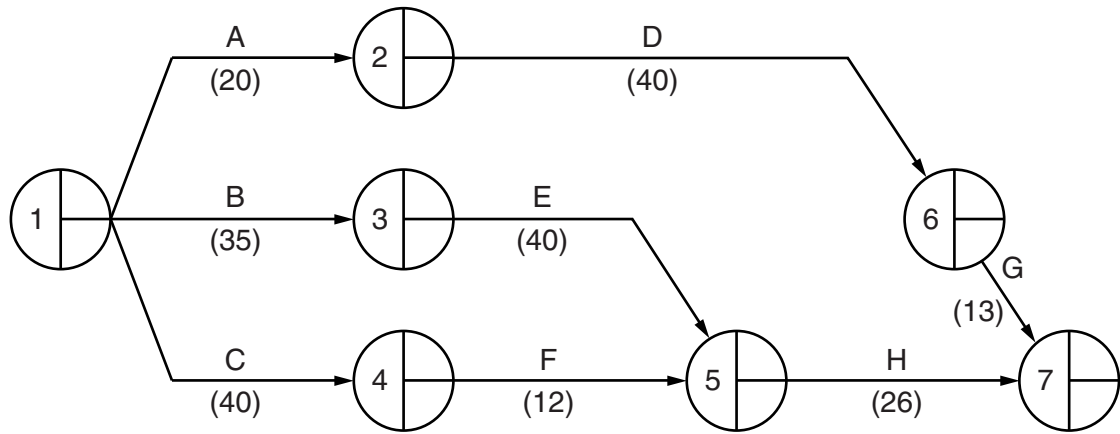

Figure 2: Network diagram

20 Refer to Figure 2 where the brackets () indicate days duration for each activity. The total float for activity F is:

- A** 12 days.
- B** 20 days.
- C** 23 days.
- D** 52 days.

Section 2: Case Study

Answer all questions in this section.

You are advised to spend 1 hour 20 minutes on this section.

WestCentral Trains (WCT)

WCT is one of the country's Train Operating Companies (TOCs). These companies purchase franchises from the Government to operate rail services on certain routes. The Government is now proposing a change of policy – extending the franchises from 8 to 15 years. Although this would reduce competition for each franchise, as there would be fewer opportunities for rivals to bid for them, it gives each TOC the ability to plan and invest for the long term. 5

The franchises can be withdrawn if minimum performance standards are not achieved. These Government-imposed standards apply to train punctuality, overcrowding limits and the quality of customer service. WCT owns and manages the stations along the franchised routes but WCT leases trains from the train leasing companies. Leasing charges have been relatively low in recent years due to low interest rates. 10

WCT operates several routes in the Midlands. The company receives an annual subsidy from the Government for operating some loss-making routes that are considered to be vital for the local economy or offer environmental benefits. WCT has indicated that the number of trains on these routes would be cut without the subsidy. It has lobbied the Government to maintain its current policy despite the Government's aim to cut the budget deficit. 15

Appendix 1 shows the trend in rail passenger numbers nationally. The general view of the rail industry is that the slow economic growth and reduced disposable incomes of many consumers would combine to reduce passenger growth and TOC profitability for several years.

Investment of £10m planned

One route that WCT operates, the Midway Line, is experiencing falling revenue and ticket sales. A market survey provided the following information. 20

- A new bypass close to the train route has increased the number of car journeys.
- Many potential passengers were unaware of the improved new trains that WCT had introduced. These have resulted in reduced journey times.

WCT management is planning a £10m investment to improve the stations on the Midway Line. The stations would be redecorated and new security cameras and alarms would be fitted. Additional 'smart ticket' machines would be installed. All of these measures would reduce station staffing needs, especially at off-peak times. To cope with the planned increase in passenger numbers some additional trains would be operated requiring additional drivers and conductors. Forecast net cash flows following the proposed investment are shown in Table A. 25 30

	Year 0	Year 1	Year 2	Year 3	Year 4	Year 5
Net cash flows	(£10m)	£2m	£4m	£4m	£6m	£7m

Table A: Forecast net cash flows following investment in the Midway Line

Promotion strategy needed

The Marketing Director, Sheila Khan, has been asked to draw up a promotion strategy for the Midway Line once the station investment is completed. She has decided to focus on increasing awareness amongst the travelling public of the benefits of travel on the Midway Line. Sheila is considering using both advertising and other sales promotion tactics. It is well known in the rail industry that advertising elasticity of demand is low but she believes that this is due to many of the adverts being poorly targeted. 35

Workforce planning – the most important factor?

The Human Resources Director, James Hill, stated that ‘an effective workforce plan will be the crucial factor determining the success of this project’. His argument is based on the following two factors. 40

- The expected cost savings depend on staffing cutbacks within the stations. If these are not handled sensitively – for example, by offering displaced workers the chance to apply for vacancies elsewhere within WCT – the trade union could take disruptive action.
- The cost of employing additional train operating staff would be reduced if temporary and part-time contracts were offered until the level of increased demand for the Midway Line was fully established. 45

Appendix 1: Passenger journeys on Britain’s rail network

(Source: Office of Rail Regulation.)

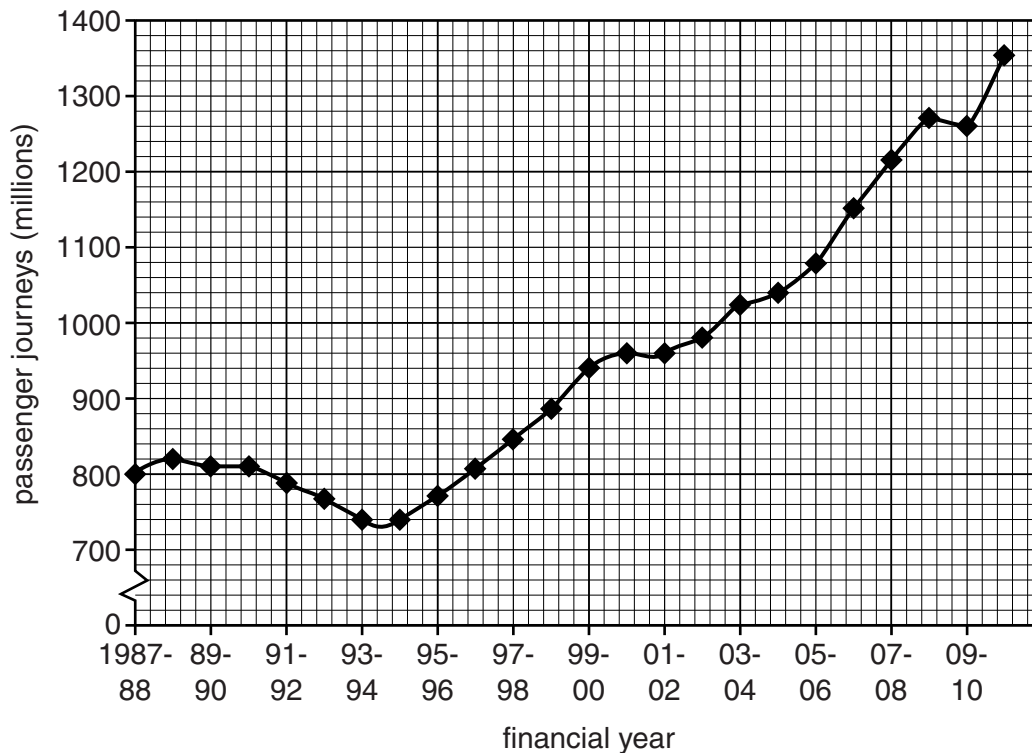

Appendix 2: Discount factors at 10% discount rate

Year 1	0.91
Year 2	0.83
Year 3	0.75
Year 4	0.68
Year 5	0.62

- 21 (a)** Calculate for the Midway Line improvement project:
- (i)** payback period [1]
 - (ii)** net present value using a discount rate of 10% [Appendix 2 gives the discount factors]. [3]
- (b)** Briefly assess the importance of these results to WCT's management when taking the investment decision. [6]
- 22** Evaluate the extent to which 'an effective workforce plan will be the crucial factor determining the success of this project'. (Lines 39 – 40) [10]
- 23** Recommend and justify an appropriate promotion strategy for the Midway Line after the investment is completed. [10]
- 24** Discuss the likely impact of possible changes in Government policy on the profitability of Train Operating Companies such as WCT. [10]

Section 3: Essay

Answer one question in this section.

You are advised to spend 45 minutes on this section. Relevant references to real world business examples will be expected.

- 25** 'The only brands that will be big in the future will be those that tap into the social changes that are taking place.' Sir Michael Perry, Chairman of Centrica plc.

Discuss the extent to which you agree with this statement. [40]

- 26** Increased globalisation has led to substantial increases in world trade, reductions in trade barriers and freer movement of capital and people.

In the light of these developments, discuss how UK businesses might achieve competitive advantage within the industry in which they operate. [40]

- 27** Three barriers to change within an organisation are lack of employee involvement, poor communication and unwillingness to accept new culture.

Evaluate how businesses undergoing significant change might overcome these barriers. [40]

- 28** 'Time waste differs from material waste in that there can be no salvage. The easiest of all wastes and the hardest to correct is the waste of time, because wasted time does not litter the floor like wasted material.' Henry Ford.

Evaluate the importance to business success of reducing waste. [40]

Copyright Acknowledgements:

Appendix 1 © Office of Rail Regulation.

Permission to reproduce items where third-party owned material protected by copyright is included has been sought and cleared where possible. Every reasonable effort has been made by the publisher (UCLES) to trace copyright holders, but if any items requiring clearance have unwittingly been included, the publisher will be pleased to make amends at the earliest possible opportunity.

University of Cambridge International Examinations is part of the Cambridge Assessment Group. Cambridge Assessment is the brand name of University of Cambridge Local Examinations Syndicate (UCLES), which is itself a department of the University of Cambridge.