

**BUSINESS AND MANAGEMENT**

9771/01

Paper 1 Business Concepts

May/June 2014

2 hours 30 minutes

Additional Materials: Answer Booklet/Paper

**READ THESE INSTRUCTIONS FIRST**

If you have been given an Answer Booklet, follow the instructions on the front cover of the Booklet.

Write your Centre number, candidate number and name on all the work you hand in.

Write in dark blue or black pen.

You may use an HB pencil for any diagrams or graphs.

Do not use staples, paper clips, glue or correction fluid.

**DO NOT WRITE IN ANY BARCODES.**



**Section 1**

Answer **all** questions.

The Insert contains the multiple-choice answer sheet on which you write your answers to Section 1.

For each question there are four possible answers **A, B, C** and **D**.

Choose the **one** you consider correct and record your choice **on the Insert**.

Each correct answer will score one mark. A mark will not be deducted for a wrong answer.

**Section 2**

Answer **all** questions.

**Section 3**

Answer **one** question.

You are advised to spend 25 minutes on Section 1, 1 hour 20 minutes on Section 2, and 45 minutes on Section 3.

**At the end of the examination, fasten all your work securely together including your answers on the multiple-choice Insert.**

The number of marks is given in brackets [ ] at the end of each question or part question.

This document consists of **12** printed pages and **1** Insert.

**Section 1: Multiple Choice**

**Answer all questions in this section.**

**Record your answers on the Insert.**

**You are advised to spend 25 minutes on the 20 questions in this section.**

- 1 Which one of the following is a primary aim of customer relationship marketing?
- A Attract new customers  
 B Increase loyalty of existing customers  
 C Increase product differentiation  
 D Reduce the need for market research
- 2 The DAGMAR model is based on taking a consumer through which sequence of stages?
- A Unawareness, attention, interest, desire, action  
 B Unawareness, awareness, comprehension, conviction, action  
 C Unawareness, attention, awareness, desire, action  
 D Unawareness, conviction, desire, action, comprehension
- 3 According to Herzberg, which of the following are key features of job enrichment?
- A A range of tasks with increased autonomy  
 B Frequent breaks and increased number of job tasks  
 C Horizontal job loading leading to job enlargement  
 D Working in groups with more opportunities to increase pay

Average total cost of producing 10 units per week	£400
Average fixed cost at production level of 10 units per week	£66
Average total cost of producing 11 units per week	£380

**Table 1**

- 4 Based on the data in Table 1, the marginal cost of producing the 11th unit per week is:
- A £20  
 B £40  
 C £66  
 D £180

All figures £000	September	October	November
Cash inflows:			
Cash sales	55	60	75
Payments from debtors	15	18	20
Total cash inflows	70	78	95
Cash Outflows:			
Materials	24	26	28
Labour	20	24	30
Overheads	20	20	25
Total cash outflows	64	70	83
Opening cash balance	(34)	(28)	(20)
Net cash flow	6	8	12
Closing cash balance	(28)	(20)	(8)

Table 2

- 5 The cash flow forecast shown in Table 2 must be amended in the light of new information. Cash sales in October are now expected to be 20% higher. Assume no other changes. The new closing cash balance (£000) in November will be:
- A (20)
  - B (4)
  - C 4
  - D 20

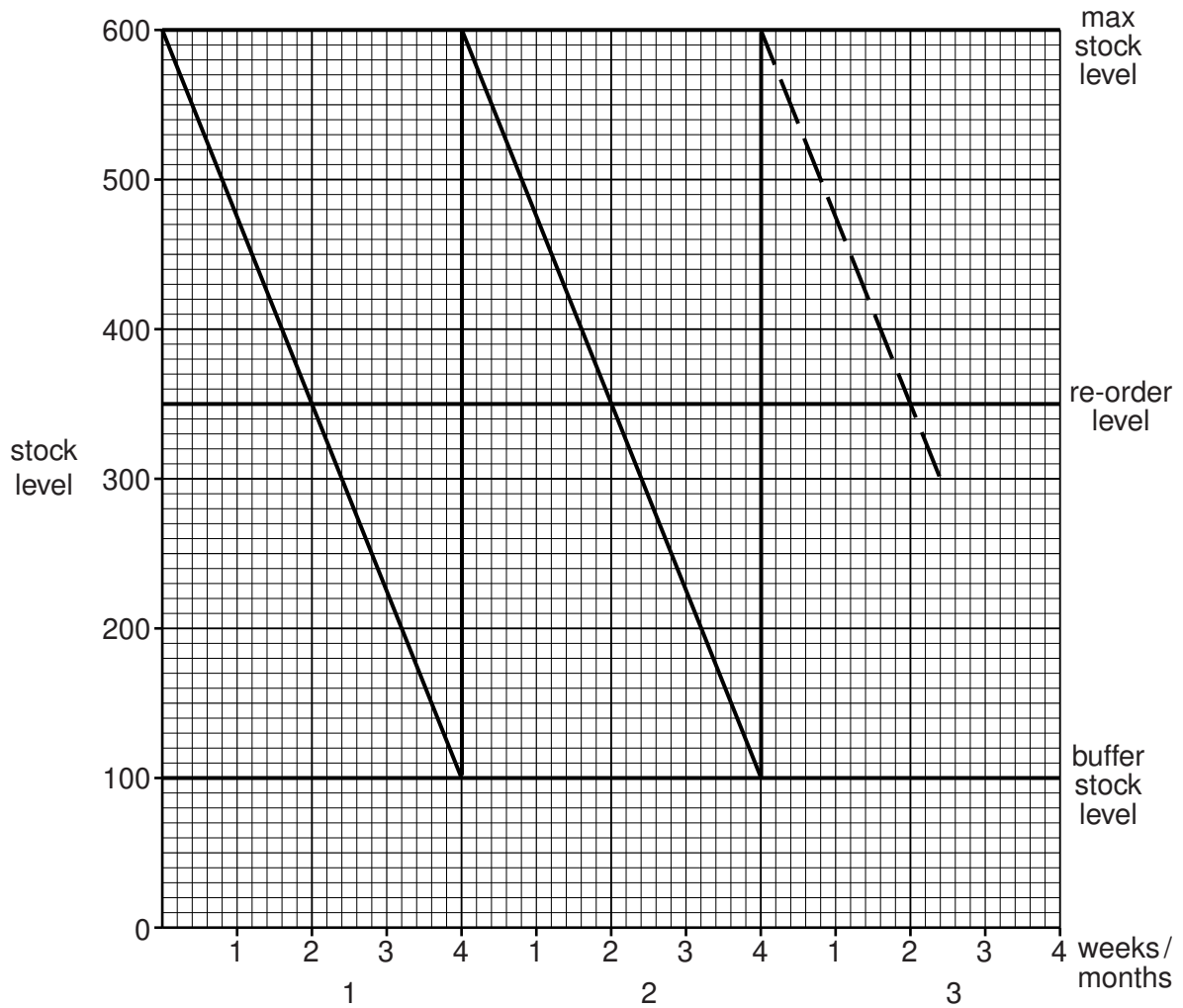

**Figure 1: Stock control graph**

- 6 The lead time for the delivery of new stock deliveries is:
- A 1 week
  - B 2 weeks
  - C 3 weeks
  - D 4 weeks
- 7 The average weekly rate of stock usage is:
- A 100 units
  - B 125 units
  - C 150 units
  - D 500 units

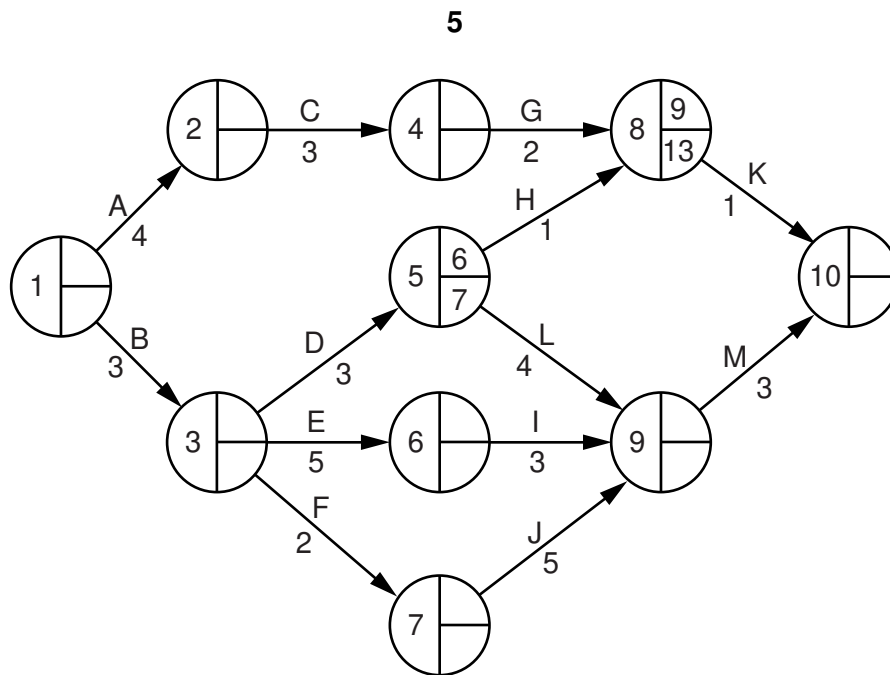

**Figure 2: Network diagram for a project**

- 8 The network diagram above shows the activities and their durations in weeks necessary for the completion of a project. Which one of the following combinations of activities represents the critical path?
- A B, D, L, M
  - B A, C, G, K
  - C B, F, J, M
  - D B, E, I, M
- 9 What is the total float time, in weeks, on activity H?
- A 2
  - B 5
  - C 6
  - D 7

- 10 One of the potential limitations of the Average Rate of Return (ARR) method of investment appraisal is that:
- A no account is taken of the profit after the payback period.
  - B the adjustment for the time value of money is complex and time consuming.
  - C no account is taken of the initial investment cost.
  - D no account is taken of the fall in value of money over time.

Country	Ford's Sales	Ford's share of car market in each country (by volume)
Britain	11300	15.5%
Italy	11200	7.9%
France	10700	5.4%
Russia	9200	4.3%

**Table 3: Ford Cars – 4 European markets by volume of sales – February 2012**

- 11 Based on the data in Table 3, the country with the largest total car market in February 2012, by volume, was:
- A Britain.
  - B France.
  - C Italy.
  - D Russia.

- 12** It has been estimated that in country A during 2012 average household incomes fell by 5%. The following sales data were also estimated during 2012:

Rice	Demand increased by 5%
Steak	Demand fell by 15%
Orange juice	Demand fell by 2%
Bread	Demand remained unchanged

Which one of the following statements is correct, based on these estimates?

- A** Steak is an inferior good.
- B** The income elasticity of demand for these products is negative apart from rice.
- C** The price elasticity of demand for both steak and orange juice is positive.
- D** The income elasticity of demand for rice is negative.
- 13** In its March 2012 budget, the UK government announced a reduction in corporation tax rates. The most likely reason for this decision was to:
- A** increase consumer spending.
- B** increase business investment spending.
- C** reduce prices as corporation tax is an indirect tax on goods and services.
- D** reduce employment levels as businesses will switch to capital intensive methods of production.
- 14** The most likely sequence of activities when determining a new marketing plan for a product is:
- A** audit, objectives, strategy, review.
- B** audit, strategy, SWOT, budget.
- C** budget, strengths, tactics, review.
- D** SWOT, objectives, review, strategy.

- 15** An entrepreneur is planning to start up a take-away food business. She has estimated that the average revenue per customer will be £12. The direct costs are likely to be 25% of revenue. The estimated monthly fixed costs are £1350.

The estimated break-even number of customers each month is:

- A** 15.
  - B** 90.
  - C** 150.
  - D** 1350.
- 16** Which one of the following statements about Porter's 5 forces analysis is true?
- A** It assesses the market share and market growth of a firm's products.
  - B** It assesses the competitive rivalry that exists in a market.
  - C** It explains that a business can protect itself from competitive forces by developing similar products to those of rivals.
  - D** It explains that a market becomes less competitive when it is easier for a customer to switch to substitute products.
- 17** Which one of the following is the most likely reason for a 'leveraged buyout' of a public limited company?
- A** The new owners will have control over the business with relatively little equity stake.
  - B** The interest costs paid by the business will fall.
  - C** The business is owned by the Government which wanted to raise finance.
  - D** Existing creditors of the business will no longer carry any risk of the business failing.
- 18** In April 2012, the UK Competition Commission (CC) approved BAA's sale of Edinburgh airport to Global Infrastructure Partners. This followed an earlier CC report that required BAA to sell 3 of its 7 UK airports. The most likely reason for CC's findings regarding BAA is:
- A** BAA's market share of the UK airport market was growing but was less than 25%.
  - B** BAA was becoming less competitive and making losses due to diseconomies of scale.
  - C** BAA's market share of the airport market was considered to be potentially anti-competitive.
  - D** BAA was making large profits due to economies of scale.



- 19 Which one of the following statements about the business cycle is correct?
- A An economic boom is often associated with rising employment.
  - B Most businesses experience reduced price sensitivity for their products during a recession.
  - C An increase in Government spending is likely to cause a recession.
  - D Demand for housing and consumer durable products is likely to fall during the recovery phase.
- 20 In October 2012, the UK Government announced an increase in the national minimum wage for workers aged 21 and over of 11p to £6.19 per hour. There was no change made to the lower rate of minimum wage paid to workers less than 21.

Which one of the following is the most likely consequence of these decisions?

- A Supply of labour aged below 21 will increase.
- B Demand for labour of all ages will fall.
- C Supply of labour aged more than 21 will increase.
- D Net immigration to the UK of people below working age will rise.

## Section 2: Case Study

Answer all questions in this section.

You are advised to spend 1 hour and 20 minutes on this section.

### Construction business sees new opportunities

Advanced Joinery Limited (AJL) makes wooden products used in the construction industry – such as doors and window frames. AJL has gained market share in recent years despite slow economic growth. The construction industry is greatly affected by the business cycle and is also subject to seasonal variations due to the outdoor nature of most construction work. Table A shows AJL's sales in recent years. The company's Marketing Director has analysed these data using the moving average method.

Year	Quarter	Sales £000	Trend (centred moving average) £000	Seasonal variation £000
2011	1	46		
	2	54		
	3	70	55	15
	4	48	56	– 8
2012	1	50	57.25	– 7.25
	2	58	58.75	– 0.75
	3	76	60.25	15.75
	4	54	62	– 8
2013	1	56	63.75	– 7.75
	2	66	65	<b>x</b>
	3	82	65.5	16.5
	4	58	65.25	<b>y</b>
2014	1	56		
	2	64		

	Quarter 1	Quarter 2	Quarter 3	Quarter 4
Average seasonal variation £000	– 7.5	0.125	<b>z</b>	– 7.75

**Table A: AJL sales' data**

The directors of AJL are planning to relocate the business to remain competitive and to offer opportunities for expansion when the economy grows more strongly. The directors have to choose between 2 possible locations. Table B provides a summary of data on these 2 locations.

A move to a new factory gives the company an opportunity to adopt new working practices. Currently, production of the best selling products is organised using flow production. Although efficient and cost effective, the method is not very flexible to changes in consumer demand such as product sizes or quality of wood used. Production workers are paid a flat rate basic wage plus a bonus based on output achieved. Both absenteeism and labour turnover are slightly higher than the national average for the industry. Workers often complain about being left for large periods in control of just one part of the production process. The Managing Director is keen to achieve high motivation levels in the new factory. She is also aware of the need for cost effective human resources strategies.

	Location P	Location Q
Number of construction businesses within 50 mile radius	200	350
Distance from nearest sea port	50 miles	10 miles
Distance from existing factory	25 miles	98 miles
Capital cost of new site	£0.5m	£0.9m
Unemployment rate	10%	14%
Annual fixed costs	£75 000	£100 000
Forecast unit contribution from most popular product line	£60	£50
Current output as % of annual capacity	80%	60%

**Table B: Data on two potential new locations for AJL's factory**

The company accountant is considering ways to raise finance for the factory relocation. The existing factory site has been valued at £300 000 but some directors of AJL believe it would be a mistake to sell this land at the present time. The local council may switch planning permission for the land to residential housing and this would double the value of the site.

AJL's existing long term loans amount to £0.2m and the current gearing ratio is 40%. The shareholders of AJL, which is a family owned private limited company, are reluctant to dilute their ownership of the business. AJL's current ratio is 1.5, the acid test ratio is 1.0 and the value of stocks is estimated to be £50 000.

- 21 (a)** Refer to Table A. Calculate the values of x, y, z. [3]
- (b)** Assess the likely value of this moving average method of sales forecasting to AJL. [7]
- 22** Discuss how AJL could motivate workers in the new factory without increasing the unit production cost. [10]
- 23** Recommend to AJL which location should be chosen for the new factory. Justify your recommendation. [10]
- 24** Discuss the most appropriate sources of finance that AJL could use for this relocation. [10]

**Section 3: Essay**

**Answer one question from this section.**

**You are advised to spend 45 minutes on this section. Relevant references to real world business examples will be expected.**

- 25** Discuss whether businesses should continue to pursue policies aimed at protecting the environment during periods of economic recession. [40]
- 26** 'Our business is about technology, yes. But it's also about operations, people and customer relationships.' Michael Dell (CEO Dell Computers).  
Assess the importance of new technology to the success of businesses. [40]
- 27** 'I never get the accountants in before I start up a business. It's done on gut feeling, especially if I can see that existing firms are taking advantage of consumers.'  
Richard Branson (Chairman Virgin Group).  
Evaluate the importance of financial planning before starting or expanding a business. [40]
- 28** Evaluate the extent to which different corporate cultures can determine the success or failure of integration between two businesses. [40]

---

Permission to reproduce items where third-party owned material protected by copyright is included has been sought and cleared where possible. Every reasonable effort has been made by the publisher (UCLES) to trace copyright holders, but if any items requiring clearance have unwittingly been included, the publisher will be pleased to make amends at the earliest possible opportunity.

Cambridge International Examinations is part of the Cambridge Assessment Group. Cambridge Assessment is the brand name of University of Cambridge Local Examinations Syndicate (UCLES), which is itself a department of the University of Cambridge.